

**W348**

3/9/08

**SHEPPACH**

**DECO-FLEX    SCROLL SAW**

Fig. 1

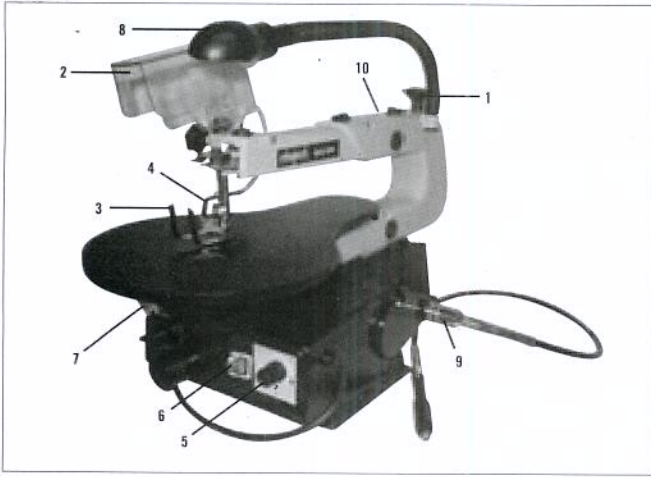

Fig. 6.1



Fig. 6.2

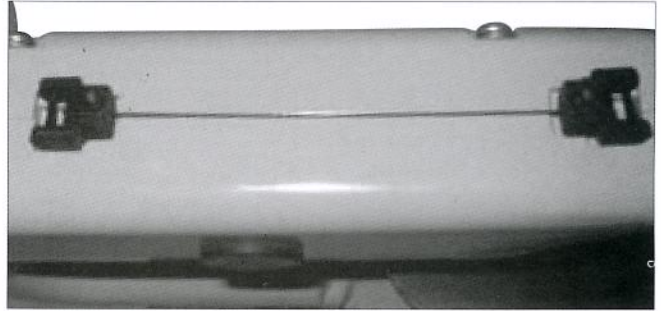

Fig. 2

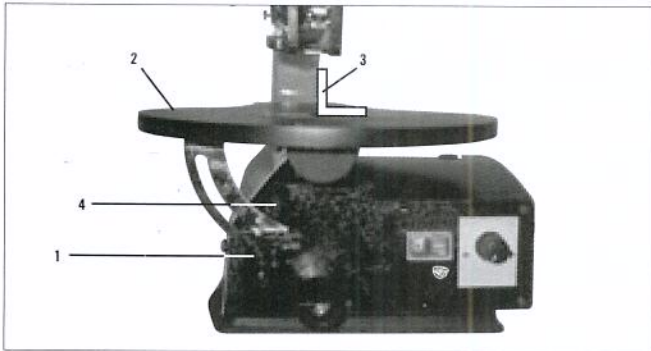

Fig. 7

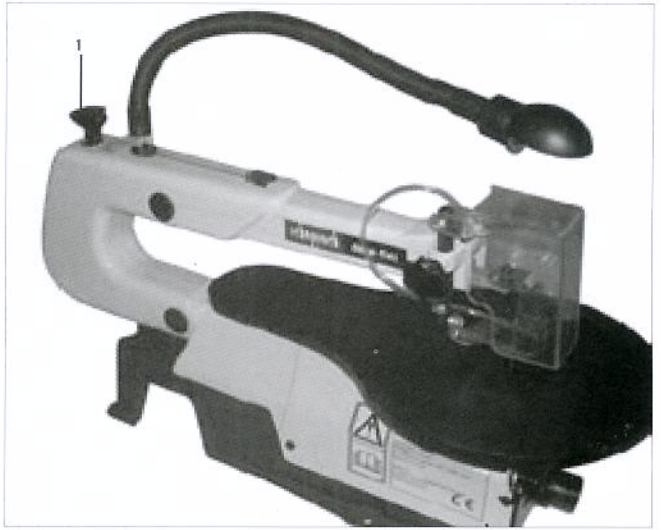

Fig. 3

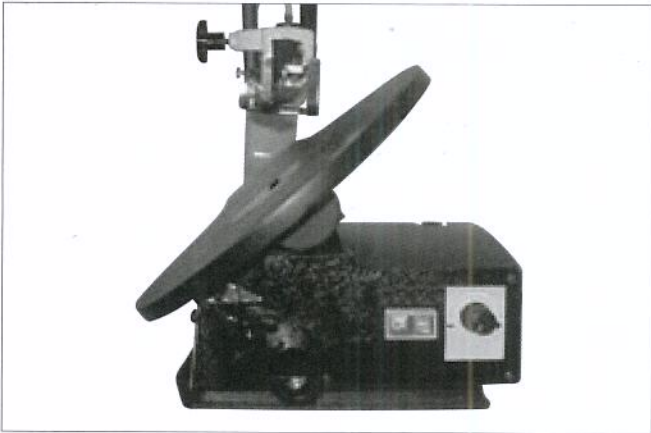

Fig. 8

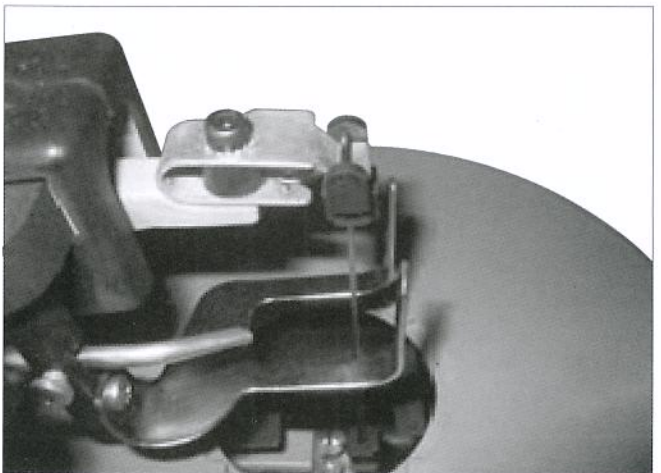

Fig. 4

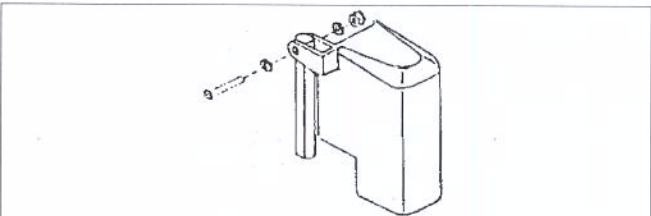

Fig. 5

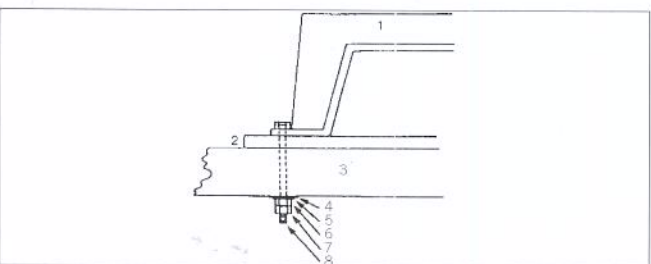

Fig. 9

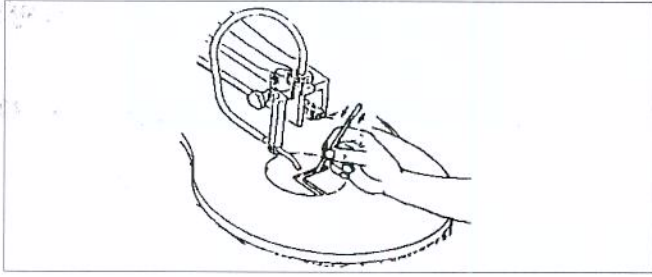

Fig. 10

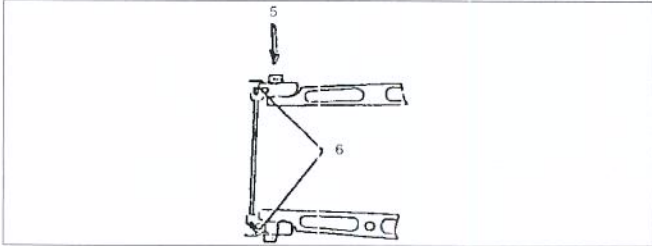

Fig. 11

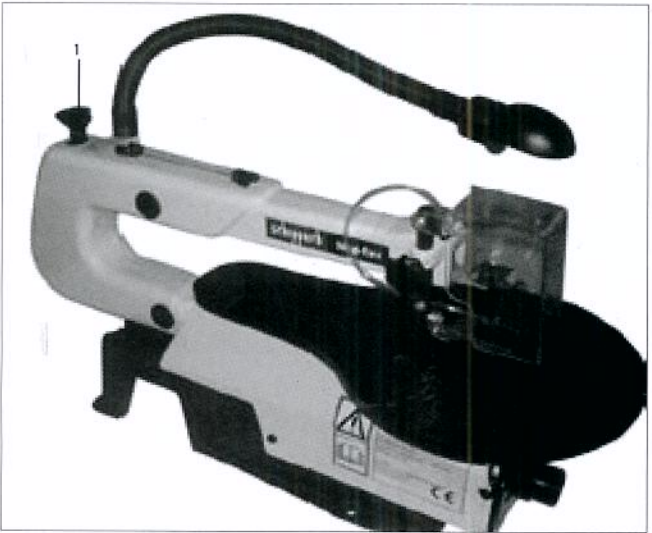

Fig. 12



Fig. 13

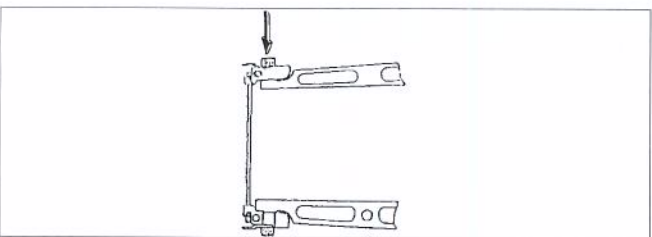

Fig. 14

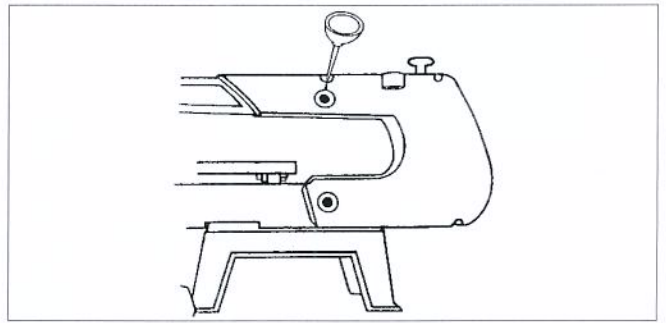

Fig. 15

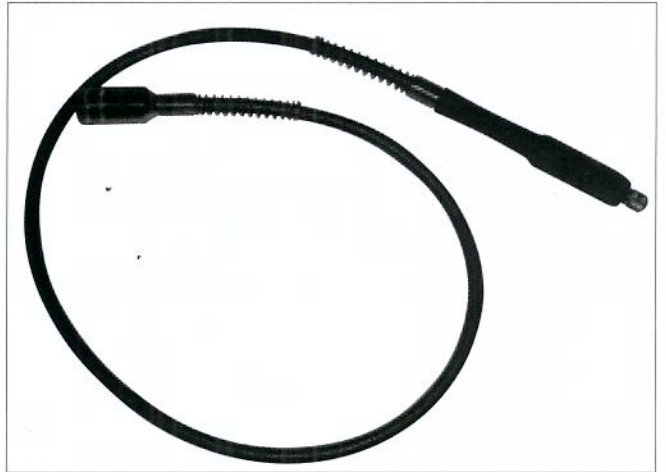

Fig. 16

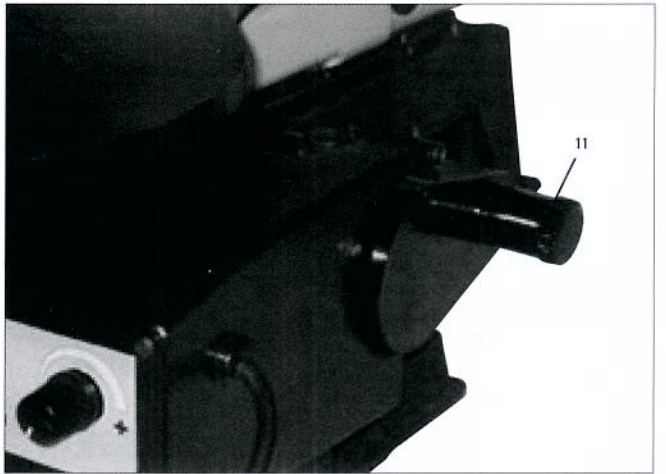
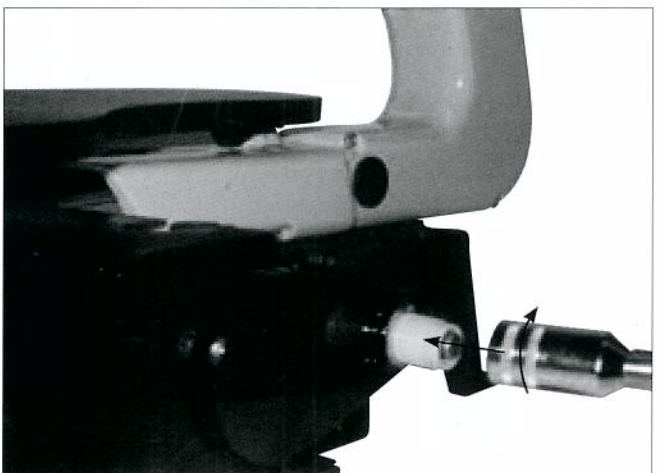

Fig. 17



## Manufacturer:

scheppach  
Fabrikation von Holzbearbeitungsmaschinen GmbH  
Günzburger Straße 69  
D-89335 Ichenhausen

## Dear customer,

we wish you a pleasant and successful working experience with your new scheppach circular saw for firewood.

According to the applicable product liability law the manufacturer of this device is not liable for damages which arise on or in connection with this device in case of:

- improper handling
- non-compliance with the instructions for use
- repairs by third party, non authorized skilled workers
- installation and replacement of non-original spare parts
- improper use
- failures of the electrical system due to the non-compliance with the electrical specifications and the VDE 0100, DIN 57113 / VDE 0113 regulations

### Recommendations:

**Read the entire text of the operating instructions prior to the assembly and operation of the device.**

These operating instructions are intended to make it easier for you to get familiar with your device and utilize its intended possibilities of use.

The operating instructions contain important notes on how to work safely, properly and economically with your machine and how to avoid dangers, save repair costs, reduce downtime, and increase the reliability and working life of the machine.

In addition to the safety regulations contained herein, you must in any case comply with the applicable regulations of your country with respect to the operation of the machine. Put the operating instructions in a clear plastic folder to protect them from dirt and humidity, and store them near the machine. The instructions must be read and carefully observed by each operator prior to starting the work. Only persons who have been trained in the use of the machine and have been informed on the related dangers and risks are allowed to use the machine. The required minimum age must be met.

In addition to the safety notes contained in the present operating instructions and the special regulations of your country, the generally recognized technical rules for the operation of wood working machines must be observed.

## General Notes

- When you unpack the device, check all parts for possible transport damages. In case of complaints the supplier is to be informed immediately.
- Complaints received at a later date will not be acknowledged.
- Check the delivery for completeness.
- Read the operating instructions to make yourself familiar with the device prior to using it.
- Only use original scheppach parts for accessories as well as for wearing and spare parts. Spare parts are available from your specialized dealer.
- Specify our part numbers as well as the type and year of construction of the device in your orders.

## Warning

To avoid electrical hazards, fire hazards, or damage to the tool, use proper circuit protection.

Your drill press is wired at the factory for 230 V operation. Connect to a 230 V/15 amp branch circuit and use a 15 amp time delay fuse or circuit breaker. To avoid shock or fire, replace power cord immediately if it is worn, cut or damaged in any way.

deco-flex	
Extent of delivery	
	Scroll saw
	Biigsame Welle
	Accessories kit
	Operating instructions
Technical data	
Dimensions L x W x H mm	630 x 320 x 380
Bench size mm	∅ 255 x 415
Saw blade length mm	133
Cutting height max. mm	50
Working depth mm	400
Lifting movement mm	15
Lifting speed 1/min (electronical)	550 – 1650
Bench diagonal adjustment left degrees	0 – 45
Weight kg	14,5
Suction connection piece ∅ mm	35
Motor	
Electrical motor	230 V/50 Hz
Power consumption P1 W	90
Sound pressure level on operator's ear measured in accordance with DIN 45635 with max. speed during idle running	76 dB (A)

## Special accessories

Pin saw blade-universal  
135 x 2,0 x 0,25 Z 10  
blade mm 1 set = 6 pieces, Article No. **8800 0011**

Pin saw blade- wood/plastic mm  
135 x 2,0 x 0,25 Z 7  
1 set = 6 pieces, Article No. **8800 0012**

Pin saw blade-wood mm  
135 x 3,0 x 0,5 Z 4  
1 set = 6 pieces, Article No. **8800 0013**



**In these operating instructions we have marked the places that have to do with your safety with this sign.**

## General Safety Rules

**WARNING! When using electric tools basic safety pre-cautions should always be followed to reduce the risk of fire, electric shock and personal injury.**

Read all these instructions before attempting to operate this product. Save these instructions for future reference.

- Keep work area clear. Cluttered areas and benches invite injuries.

- Consider work area environment. Do not expose tools to rain. Do not use tools in damp or wet locations. Keep work area well lit. Do not use tools in the presence of flammable liquids or gases.
- Guard against electric shock. Avoid body contact with earthed or grounded surfaces
- Keep other people away. Do not let others, especially children, not involved in the work touch the tool or the extension lead and keep them away from the work area.
- Store idle tools. When not in use, tools should be stored in a dry locked-up place, out of reach of children.
- Do not force the tool. It will do the job better and safer at the rate for which it was intended.
- Use the right tool. Do not force small tools to do the job of a heavy duty tool. Do not use tools for purposes not intended; for example do not use circular saws to cut tree limbs or logs.
- Dress properly. Do not wear loose clothing or jewellery they can be caught in moving parts. Non-skid footwear is recommended when working outdoors. Wear protective hair covering to contain long hair.
- Use protective equipment. Use safety glasses. Use face or dust mask if cutting operations create dust.
- Connect dust extraction equipment. If devices are provided for the connection of dust extraction and collecting equipment, ensure these are connected and properly used.
- Do not abuse the lead. Never pull the power cable to disconnect it from the socket. Keep the lead away from heat, oil and sharp edge.
- Secure work. Where possible use clamps or a vice to hold the work. It's safer than using your hand.
- Don't over reach. Keep proper footing and balance at all times.
- Maintain tools with care. Keep cutting tools sharp and clean for better and safer performance. Follow instructions for lubricating and changing accessories. Inspect power cables periodically and if damaged have them replaced by an authorised service facility. Inspect extension cables periodically and replace if damaged. Keep handles dry, clean and free from oil and grease.
- Disconnect tools. When not in use, before servicing and when changing accessories such as blades, bits, cutters, disconnect tools from the power supply.
- Remove adjusting keys and wrenches. Form the habit of checking to see that keys and adjusting wrenches are removed from the tool before turning it on.
- Avoid unintentional starting. Ensure switch is in 'off' position when plugging in.
- Use outdoor extension leads. When the tool is used outdoors, use only extension leads intended for outdoor use and so marked.
- Stay alert. Watch what you are doing, use common sense and do not operate the tool when you are tired.
- Check damaged parts. Before further use of the tools, it should be carefully checked to determine that it will operate properly and perform its intended function. Check the alignment of moving parts, binding of moving parts, breakage of parts, mounting and any other conditions that may affect its operation. A guard or other part that is damaged should be properly repaired or replaced by an authorised service centre unless otherwise indicated in this instruction manual. Do not use the tool if the switch does not turn on and off.
- Warning. The use of any accessory or attachment other than one recommended in this instruction manual may present a risk of personal injury.

- Have your tool repaired by a qualified person. This electric tool complies with the relevant safety rules. Repairs should only be carried out by a qualified person using original spare parts, otherwise this may result in considerable danger to the user.

#### **Additional Safety Rules for Scroll Saws**

- This scroll saw is intended for use in dry conditions, and for indoor use only.
- Do not cut pieces of material too small to hold by hand outside the blade guard.
- Avoid awkward hand positions where a sudden slip could cause a hand to move into the blade.
- Always use the blade guard to avoid possible injury due to blade breakage.
- Never leave the scroll saw work area with the power ON, or before the machine has come to a complete stop.
- Do not perform layout, assembly or set up work on the table while the cutting tool is in operation.
- Never turn your scroll saw on before clearing the table of all objects: (tools, scraps of wood, etc) except for the workpiece and related feed or support devices for the operation planned.

### **Proper use**

**CE tested machines meet all valid EC machine guidelines as well as all relevant guidelines for each machine.**

- The machine must only be used in technically perfect condition in accordance with its designated use and the instructions set out in the operating manual, and only by safety-conscious persons who are fully aware of the risks involved in operating the machine. Any functional disorders, especially those affecting the safety of the machine, should therefore be rectified immediately.
- The safety, work and maintenance instructions of the manufacturer as well as the technical data given in the calibrations and dimensions must be adhered to.
- Relevant accident prevention regulations and other, generally recognized safety-technical rules must also be adhered to.
- The machine may only be used, maintained, and operated by persons familiar with it and instructed in its operation and procedures. Arbitrary alterations to the machine release the manufacturer from all responsibility for any resulting damages.
- The machine may only be used with original accessories and tools made by the manufacturer.
- Any other use exceeds authorization. The manufacturer is not responsible for any damages resulting from unauthorized use; risk is the sole responsibility of the operator.

### **Remaining hazards**

**The machine has been built using modern technology in accordance with recognized safety rules. Some remaining hazards, however, may still exist.**

- Long hair and loose clothing can be hazardous when the work piece is rotating. Wear personal protective gear such as a hair net and tight fitting work clothes.
- Saw dust and wood chips can be hazardous. Wear personal protective gear such as safety goggles and a dust mask.
- The use of incorrect or damaged mains cables can lead to injuries caused by electricity.
- Even when all safety measures are taken, some re-

maining hazards which are not yet evident may still be present.

- Remaining hazards can be minimized by following the instructions in „Safety Precautions“, „Proper Use“ and in the entire operating manual.
- Do not force the machine unnecessarily: excessive cutting pressure may lead to rapid deterioration of the blade and a decrease in performance in terms of finish and cutting precision.
- Avoid accidental starts: do not press the start button while inserting the plug into the socket.

## Scroll Saw Design Features, Fig. 1

- 1 Clamping screw:** for removing the saw blade.
- 2 Blade guard:** protects your hands from injury.
- 3 Work piece holder**
- 4 Shavings blower:** keeps the workpiece area free from dust.
- 5 electronical speed switch**  
**deco 402: Speed switch**
- 6 On/Off switch**
- 7 Angle scale:** you can read the angle position of the table with this scale.
- 8 Lighting**
- 9 Flexible shaft** with drill chuck
- 10 Setting gauge** for saw blades without pin

## Installation

### Setting the saw bench, Fig. 2

#### Setting the angle scale

- Release the star button (1) and bring the saw bench (2) to a right angle (3) in relation to the saw blade.
- Use a 90° angle to measure the right angle between the blade and the bench. The saw blade be 90° to the angle.
- Close the star button again when the distance between the blade and the 90° angle is at a minimum. The bench should then be at 90° to the saw blade.
- Release the lock screw and bring the indicator to the zero position. Fasten the screw. Please note: the angle scale is a useful piece of supplementary equipment, but should not be used for precision work. Use scrap wood for saw tests, adjust the bench if necessary.

**Note: The bench should not be on the motor block, this can cause undesirable noise.**

### Horizontal saw bench and diagonal cuts, Fig. 2+3

- The saw bench can be positioned into a 45° diagonal position or be left in the horizontal position.
- You can read off the approximate slope angle by using the angle scale located under the work bench. For more exact adjustment, use scrap wood for some saw tests; adjust the bench if necessary.

### Blade guard assembly, Fig. 4

Install the blade guard to the holder as shown in the diagram. Secure the screws with a nut and washer.

- Lift the saw onto the frame and base and push it onto the workbench.
- Familiarize yourself with the saw operating elements and features.

### Mounting the saw on a work bench, Fig. 5

- A workbench made from solid wood is better than one made of plywood, as interfering vibrations and noise are

more noticeable with plywood.

- The necessary tools and small parts for assembling the saw on a workbench are not supplied with the saw. However, use equipment of at least the following size:

- 1 Saw body
- 2 Foam rubber base
- 3 Work bench
- 4 Flat seal
- 5 Washer
- 6 Hexagonal nut
- 7 Lock nut
- 8 Hexagonal bolt

#### Quantity Description

- 4 Hexagonal bolts (6mm) 1/4-20 x length
- 4 Flat seal (7mm) 9/321.0
- 4 Washers (7mm) 9/321.0.
- 8 Hexagonal nuts (6 mm) 1/4-20

First of all, drill holes into the seating surface and then insert the screws.

- A foam rubber base for reduction of noise is not supplied with the saw either. However, we expressly recommend that you use such a base to keep vibration and noise to a minimum. Ideal size 400 x 240 mm.

### Changing the saw blades

**Warning: Switch off the saw and remove the mains supply plug before installing saw blades in order to avoid injuries caused by unintentional activation of the saw.**

#### A. Flat saw blades

##### A. Flat saw-blades

Use the adapter (fig 6) with flat saw-blades.

The saw-blade is fixed with Allen screws.

##### A 1 Saw-blade removal, fig. 7+8

- Extract the saw-blade by sliding the table's inlay up, then unscrew the tightening screw (1).
- Slightly press the upper arm (5) down fig. (10).
- Then remove the sawblade by pulling it forward out of the supports and through the access perforation in the table.

##### A 2 Inserting the saw-blade:

- Put the saw-blade with the two adapters into the lower support, the other end into the upper support.
- Slightly press the upper arm (5) down (fig 10) before hooking it in.
- Tighten the blade with the tightening screw (1) (fig. 11) by rotating it clockwise. Check the tightness of the blade. Keep on rotating clockwise in order to tighten the blade even more.

#### B. Saw-blade with pins

##### B 1 Saw blade removal, fig. 7 + 8

- Extract the saw-blade by first unscrewing the tightening screw (1).
- Remove the saw-blade from the upper and lower support by slightly pressing the saw's upper arm down (fig. 10).

##### B 2 Inserting the saw-blade fig 9-12

- Lead one end of the saw-blade through the perforation in the table and insert the saw-blade pins into the notch. Repeat this procedure at the upper blade support.
- Before hooking it in, slightly press the saw's upper arm down. Fig 10; Nr. 5
- Check the position of the blade pins at the supports (fig 12).
- Tighten the blade by means of the tightening screw. Check the blade's tightness. Keep on rotating clockwise in order to tighten the blade even more. (Fig. 11).

## Basic operation

A scroll saw is fundamentally a „curve cutting tool“ but which can also carry out straight and angled edge cuts. Familiarise yourself with the following important points prior to commissioning the saw.

- The saw does not automatically cut wood. You must feed the wood against the saw blade manually.
- The cutting process occurs on 1 y while the blade is moving downwards.
- Feed the wood slowly against the saw blade as the saw blade teeth are small and cut only while moving downwards.
- All persons carrying out work with the saw require training. The saw blade may break easily during this training time (while the operator is still unfamiliar with the saw).
- The saw is best suited for sheets of wood less than 2.5 cm thick.
- Feed the wood especially slowly against the blade and avoid abrupt curves to prevent the saw blade from breaking, if you wish to cut wood sheets thicker than 2.5 cm.
- Saw blade teeth blunten over time, saw blades must be replaced. The saw blades are sufficient for 1/2 to 2 operating time depending upon the type of wood.
- Try and make sure that the saw blade follows the grain of the wood in order to obtain a clean cut.
- The saw speed must be reduced to minimum when cutting precious and non-ferrous metals.

### Inside cuts

**Warning: Switch off the saw and remove the mains supply plug before installing saw blades in order to avoid injuries caused by unintentional activation of the saw.**

This saw is suited also to inside cuts not starting at the edge of the work piece. Proceed as follows:

- Drill a 6 mm hole in the work piece.
- Loosen the blade tensioner and release the tension in the blade.
- Place the bore hole over the saw blade slot in the work bench.
- Install the saw blade through the hole in the work piece and through the work blade slot, and fasten the blade to the holders.
- When you have completed the inside cut, remove the saw blade and then remove the workpiece from the bench.

### Flexible shaft, Fig. 15

- Remove protective cap from the threaded bushing (Fig. 16).
- Place flexible shaft onto the threaded bushing (Fig. 17).
- Clamp tool in the drill chuck (D 3.2).
- Firmly hold threaded shaft at the handle and switch on the speed control.
- Having finished the work, remove the flexible shaft and place the protective cap in place. Attention: When working with the flexible shaft, cover the saw blade with the blade guard.

## ⚠ Electrical connection

The installed electric motor is completely wired ready for operation.

The customer's connection to the power supply system, and any extension cables that may be used, must conform with local regulations.

### Important remark:

The motor is automatically switched off in the event of an overload. The motor can be switched on again after a cooling down period that can vary.

### Defective electrical connection cables

Electrical connection cables often suffer insulation damage.

Possible causes are:

- Pinch points when connection cables are run through window or door gaps.
- Kinks resulting from incorrect attachment or laying of the connection cable.
- Cuts resulting from running over the connecting cable.
- Insulation damage resulting from forcefully pulling out of the wall socket.
- Cracks through aging of insulation.

Such defective electrical connection cables must not be used as the insulation damage makes them **extremely hazardous**.

Check electrical connection cables regularly for damage. Make sure the cable is disconnected from the mains when checking.

Electrical connection cables must comply with the regulations applicable in your country.

### Single-phase motor

- The mains voltage must coincide with the voltage specified on the motor's rating plate.
- Extension cables up to a length of 25 m must have a cross-section of 1.5 mm<sup>2</sup>, and beyond 25 m at least 2.5 mm<sup>2</sup>.
- The connection to the mains must be protected with a 16 A slow-acting fuse.

Only a qualified electrician is permitted to connect the machine and complete repairs on its electrical equipment.

In the event of enquiries please specify the following data:

- Motor manufacturer
- Type of current of the motor
- Data recorded on the machine's rating plate
- Data recorded on the switch's rating plate

If a motor has to be returned, it must always be dispatched with the complete driving unit and switch.

## ⚠ Maintenance

**Warning:** In the interests of operational safety, always switch off the saw and remove the mains plug before carrying out maintenance work.

### General

Re-application of the wax coating on the workbench makes feeding the workpiece to the blade easier.

### Motor

The mains cable should be replaced immediately if pulled out, cut or damaged in any other way.

Do not lubricate the motor bearings or internal parts!

### Saw arm bearings

Lubricate the saw arm bearings every 50 hours. Proceed as follows (Fig. 14).

- Turn the saw to the side
- Apply a generous amount of SAE 20 oil to the shaft end and bronze bearings.
- Let the lubricant oil work in overnight.
- Repeat the procedure the next day on the other side of the saw.

## EC Declaration of Conformity

We herewith declare, **scheppach Fabrikation von Holzbearbeitungsmaschinen GmbH, Günzburger Str. 69, D-89335 Ichenhausen** that the machine described below due to its construction and design and in the version delivered by us complies with the relevant provisions of the following EC Directives.

In case of a modification of the machine this declaration ceases to be valid.

Machine description:  
**Scroll Saw**

Machine type:  
**deco-flex**

Applicable EC Directives:  
**Machinery Directive 98/37/EC, Low Voltage Directive 72/23/EEC, last modified by the Directive 93/68/EEC, EMC Directive 89/336/EEC, last modified by the Directive 93/68/EEC.**

Notified body within the meaning of Annex VII  
**TÜV Rheinland, Sicherheit und Umweltschutz GmbH, 51101 Köln**

Place, date:  
**Ichenhausen, 10.12.2004**

  
Signature:  
**On behalf of Wolfgang Windrich**

## Troubleshooting table

**Warning:** In the interests of operational safety, always switch off the saw and remove the mains plug before carrying out maintenance work.

Fault	Possible causes	Action
Saw blades break	Tension incorrectly set	Set the correct tension
	Load too great	Feed the workpiece more slowly
	Incorrect saw blade variety	Use the correct saw blades
	Workpiece not fed straight	Avoid exerting pressure from the side
Motor does not function	Mains Gable faulty	Change faulty parts
	Motor faulty	Call customer service. Do not attempt to repair the motor yourself as this should be carried out by trained personnel.
Vibration NOTE: The saw vibrates slightly when the motor is running in normal operation.	Saw incorrectly installed	Refer to the instructions given earlier in this manual for information on installing the saw
	Unsuitable underlay	The heavier the work bench is, the less the vibration. A bench made from ply wood always vibrates more than one made from solid wood. Select the work bench best suited to your working conditions
	The work bench is not screwed down or is on the motor	Tighten the locking lever
	The motor is not secured	Securely screw the motor in place
Saw blade swings out Holders not aligned straight	Holders not aligned	Loosen the screws with which the holders are fastened to the arm. Align the holders so that they are perpendicular to each other and retighten the screws.



